

Drill Doctor[®]

THE DRILL BIT SHARPENER

USER GUIDE



MODEL

500X

MODEL

750X

GET SHARP AND GET BACK TO WORK

⚠ Caution!

To reduce risk of injury, the user must read and understand this instruction manual before using product. Save these instructions for future reference.

Drill Doctor® Drill Bit Sharpener

Class I - Consumer Product DD500X and DD750X
Transportable motor-operated electric drill bit sharpener

Manufactured by Darex, LLC
Maker of Drill Doctor®, Work Sharp®, Work Sharp Culinary®
and DAREX®

Designed, constructed and certified in accordance with:
IEC 61029-1: 1990 First Edition
EN 61029-1:2009+A11:2010
EN ISO 12100:2010

Additionally in compliance with the applicable
requirements of the following Directives and Standards:

EC Machinery Directive (2006/42/EC)
EC Electromagnetic Compatibility Directive (2004/108/EC)
DC DMF (Dimethylfumarate) Regulation (2009/25/EC)
RoHS2 Directive 2011/65/EC

Thank you, for purchasing a **Drill Doctor**[®]. It is sure to become a valuable tool because you will always have sharp drill bits before a project, during a project, and after a project.

As president of this company, I am very proud of the quality of our products—and I am equally proud of the great people at **Darex**[®] who design and produce them. If you have questions or need help with your **Drill Doctor**[®], please contact us and one of our customer representatives will be there to help. We support what we build!

This User's Guide will help you learn to operate your Drill Doctor quickly & easily. Please visit our website at www.drilldoctor.com to:

- View instructional videos
- Submit your warranty registration
- Review FAQs
- Contact our service department

Again, thank you for buying a **Drill Doctor**[®].

Now go enjoy its convenience and quality.

Matthew Bernard
President, **Darex**[®]

Contents

English	4
General Safety Rules.....	5
Getting to Know Your Drill Doctor ®	14
Identifying Basic Drill Bits.....	15
Anatomy of a Drill Bit.....	15
The Drill Doctor ® Sharpening Process	15
Choosing Your Drill Bit Point Angle on the	
Model DD500X.....	16
Model DD750X.....	17
Aligning the Drill Bit.....	17
Sharpening Drill Bits	19
Identifying Correctly Sharpened Drill Bits.....	21
Split Points.....	22
Identifying Correctly Split Drill Bits.....	24
Grit Tube	25
Sharpening Bits of Different Lengths, Diameters,	
and Types	25
Masonry Drill Bits	26
Adjusting Chisel and Relief Angles	27
Adjusting the Material Take-Off (DD750X only)	29
Questions and Answers	29
Drill Doctor ® Maintenance.....	32
Parts and Accessories	35
Warranty.....	36

Original Instructions

General Safety Rules

⚠️ WARNING! When using electric tools, basic safety precautions should always be followed to reduce the risk of fire, electric shock and personal injury. Read all these instructions before attempting to operate this product and save these instructions.



⚠️ WARNING! CHOKING HAZARD!

Small Parts – Not for children under 3-yrs.

Installation/Assembly

The **Drill Doctor**® is completely assembled.

Carefully unpack the power tool and set it on the table. Check to see that no damage has occurred in shipment. Check all packing materials to be sure that all parts are present. See “Getting to know your **Drill Doctor**®” for a parts identification diagram.

⚠️ WARNING! Connect to properly wired (115V or 230V, as applicable) outlet, or electrical shock may occur.

1. Work Area Safety:

- a) **Keep work area clean and well lit.** Cluttered or dark areas invite accidents.
- b) **Do not operate power tools in explosive atmospheres, such as in the presence of flammable liquids, gases or dust.** Power tools create sparks which may ignite the dust or fumes.
- c) **Keep children and bystanders away while operating a power tool.** Distractions can cause you to lose control. Do not let persons not involved in the work touch the tool or power cord.
- d) **Make workshop kid proof** with padlocks, master switches or by removing starter keys.
- e) **Securely place this tool on your workbench during use.**

2. Electrical Safety:

⚠️ DANGER! Electrical shock can kill! Read, understand and follow **ALL** safety instructions.

⚠️ WARNING! Do not expose power tools to rain or wet conditions. Water entering a power tool will increase the risk of electric shock.



- a) **Power tool plugs must match the outlet.** Never modify the plug in any way. Do not use any adapter plugs with earthed (grounded) power tools. Unmodified plugs and matching outlets will reduce risk of electric shock.
- b) **Avoid body contact with earthed or grounded surfaces, such as pipes, radiators, ranges and refrigerators.** There is an increased risk of electric shock if your body is earthed or grounded.
- c) **Do not abuse the cord.** Never use the cord for carrying, pulling or unplugging the power tool. Never yank the cord to disconnect it from the socket. Keep cord away from heat, oil, sharp edges or moving parts. Damaged or entangled cords increase the risk of electric shock.
- d) **Use proper extension cord.** Use only 3-wire extension cords that have 3-prong plugs and 3-pole receptacles that accept the power tool's plug. Make sure your extension cord is in good condition. When using an extension cord, be sure to use one heavy enough to carry the current your product will draw. Use marked outdoor extension cord leads when the tool is used outdoors.
- e) **Disconnect tools.** Always disconnect your power tool when cleaning, inspecting, and changing accessories. When not in use, disconnect from the power supply. Never touch internal parts of the sharpener when it is turned on or plugged in. The rotating diamond wheel can result in injury.
- f) **Grounding instructions.** In the event of a malfunction or breakdown, grounding provides a path of least resistance for electric current to reduce risk of electric shock. This power tool is equipped with an electric cord having an equipment-grounding conductor and grounding plug. Do not modify the plug provided. The plug must be plugged into a matching outlet that is properly installed and grounded in accordance with all codes and ordinances. Improper connection of the equipment-grounding conductor can result in a risk of electric shock. The conductor with insulation having an outer surface that is green with or without yellow stripes is the equipment-grounding conductor. If repair or replacement of the electric cord or plug is necessary, do not connect the equipment-grounding conductor to the live terminal. Check with a qualified electrician or service personnel if the grounding instructions are not completely understood, or if in doubt as to whether the tool is properly grounded. Repair or replace damaged or worn cord immediately.
- g) **When operating a power tool outdoors, use an extension cord suitable for outdoor use.** Use of a cord suitable for outdoor use reduces the risk of electric shock.

USA Only

This tool is intended for use on a circuit that has an outlet that looks like the one illustrated in Fig. A. It has a grounding plug that looks like the one in Fig. B. A temporary adapter, which looks like the adapter illustrated in Fig. C & Fig. D, may be used to connect this plug to a 2-pole receptacle as shown in Fig. D if a properly grounded outlet is not available. The temporary adapter should be used only until a properly grounded outlet can be installed by a qualified electrician. The green-colored rigid ear, lug, and the like, extending from the adapter must be connected to a permanent ground such as a properly grounded outlet box.

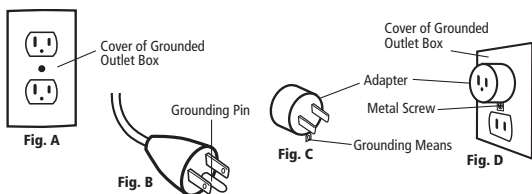

3. Personal Safety:

Sharpening operations can create hot sparks and metal debris, loud noises and dust.

- a) **Stay alert - watch what you are doing and use common sense when operating a power tool.** Do not use a power tool while you are tired or under the influence of drugs, alcohol or medication. A moment of inattention while operating power tools may result in serious personal injury.
- b) **Use personal protective equipment (PPE).** **Always wear eye protection.** Protective equipment such as dust mask, non-skid safety shoes, hard hat or hearing protection used for appropriate conditions will reduce personal injuries. 
- c) **Use ear protection during use.** *Drill Doctor*[®] unit can generate in excess of 85 dB(A) noise emissions when in operation.
- d) **Prevent unintentional starting.** Ensure the switch is in the off-position before connecting to power source and/or battery pack, and when picking up or carrying the tool. Carrying power tools with your finger on the switch, or energizing power tools that have the switch on invites accidents.

- e) **Remove any adjusting key or wrench before turning the power tool on.** A wrench or a key left attached to a rotating part of the power tool may result in personal injury.
- f) **Do not overreach. Keep proper footing and balance at all times.** This enables better control of the power tool in unexpected situations. Nonslip footwear is recommended.
- g) **Dress properly. Wear closed, non-flammable protective clothing.** Do not wear loose clothing or jewelry. Keep your hair, clothing and gloves away from moving parts. Loose clothes, jewelry or long hair can be caught in moving parts.
- h) **Secure Work. Use clamps or a vise to hold work when practical.** It's safer than using your hand and it frees both hands to operate tool.

4. Power Tool Use and Care

⚠ WARNING! Use recommended accessories. Use the power tool, accessories, abrasives, and tool bits etc., in accordance with these instructions, taking into account the working conditions and the work to be performed. Use of the power tool for operations different from those intended could result in a hazardous situation.

⚠ CAUTION! Keep power tools and work space clean for best performance and safety. Do not let sharpening debris accumulate on, in, or around the tool. Accumulated fine metal sharpening debris can be very hot and may present a fire danger if the machine or your workspace is not properly cleaned and maintained. Accumulated sharpening debris can also degrade the life of the tool and cause premature wear on some components. If sharpening debris has accumulated, do not immediately throw it into a trash receptacle without ensuring the debris is completely cool and free of heat. Improperly disposing of the accumulated sharpening debris may present a fire risk. Do not collect the sharpening debris during sharpening. This increases the risk of heat build-up in the debris and the potential for fire.

- a) **Do not force the power tool or attachment.** Use the correct power tool for your application. Do not force small tools to do the job of a heavy duty tool. The correct power tool will do the job better and safer at the rate for which it is designed.
- b) **Use the right tool.** Do not force tool or attachment to do a job for which it is not designed.
- c) **Do not use the power tool if the switch does not turn it on or off.** Any power tool that cannot be controlled with the switch is dangerous and must be repaired.
- d) **Never leave tool running unattended – Turn power off.** Do not leave the tool until it comes to a complete stop.

- e) **Disconnect the plug from the power source and/or the battery pack from the power tool before making any adjustments, changing accessories, or storing power tools.** Such preventative safety measures reduce the risk of starting the power tool accidentally.
- f) **Store idle power tools out of reach of children and do not allow persons unfamiliar with the power tool or these instructions to operate the power tool.** Power tools are dangerous in the hands of untrained users.
- g) **Keep cutting tools sharp and clean** for better and safer performance.
- h) **Follow instructions for lubricating (if applicable) and for changing accessories.**
- i) **Maintain power tools.** Check for misalignment or binding of moving parts, breakage of parts and any other condition that may affect the power tool's operation. If damaged, have the power tool repaired by an authorized service center before use. Keep handles dry, clean and free from oil and grease. Many accidents are caused by poorly maintained power tools.
- j) **Inspect tool cord periodically and if damaged have it repaired by an authorized service center.** Inspect extension cords periodically and repair if damaged.
- k) **Keep guards in place and in working order.** A guard or other part that is damaged should be properly repaired or replaced by an authorized service center unless otherwise indicated in the instruction manual.
- l) **Never stand on the power tool.** Serious injury could occur if the tool is tipped or if the sharpening edge is unintentionally contacted.
- m) **Check damaged parts.** Before further use of the tool, any part that is damaged should be carefully checked to determine that it will operate properly and perform its intended function. Check the alignment of moving parts, binding of moving parts, breakage of parts, mounting and any other conditions that may affect its operation. Any damaged part, including the switch, should be properly repaired or replaced by an authorized service center.
- n) **Do not use if the grinding wheel is damaged. Use only grinding wheels recommended by *Drill Doctor*®**

5. Service

- a) **Have your tool serviced by a qualified repair person using only identical replacement parts.** This will ensure that the safety of the power tool is maintained.

For Service in the USA, Contact:

Darex, LLC

PO Box 730
210 E Hersey St
Ashland OR 97520

Phone: (800) 418-1439

Fax: (541) 552-1377

Email: info@darex.com

- b) **Do not dispose of electrical products with household waste.** Waste electrical products should not be disposed of with household waste. Please recycle where facilities exist. Check with your local authority or retailer for recycling advice.



Specific Safety Rules

⚠ WARNING! ALWAYS use proper safety glasses. Everyday eyeglasses are NOT safety glasses. Also use face or dust mask if operation is dusty. ALWAYS wear certified safety equipment:

- ANSI Z87.1 eye protections (CAN/CSA Z94.3)
- ANSI 512.6 (53.19) hearing protection
- NIOSH/OSHA respiratory protection

⚠ WARNING! Use of this tool can generate and/or disperse dust, which may cause serious permanent respiratory or other injury. Always use NIOSH/OSHA approved respiratory protection appropriate for the dust exposure. Direct particles away from face and body.

Motor

Be sure your power supply agrees with the nameplate marking. 115 Volts means your tool will only operate on standard 60HZ household power. 230 Volts means your tool will only operate on standard 50 HZ household power. Do not operate AC tools on DC. Lower voltage will cause loss of power and can result in overheating. Using a machine on an unmatched power source voids your warranty.

Extension Cords

Make sure your extension cord is in good condition. When using an extension cord, be sure to use one heavy enough to carry the current voltage resulting in loss of power and overheating. The Drill Doctor® has a 1.75 ampere rating. The following table shows the correct size to use depending on cord length and nameplate ampere rating. If in doubt use the next heavier gauge. The smaller the gauge number the heavier the cord.

Save These Instructions

Minimum Gauge Cord Sets				
Volts	Total Length of Cord in Feet			
115V	0-25 (0-7.6m)	26-50 (7.6-15.2m)	51-100 (15.2-30.4m)	101-200 (30.4-60.9m)

Ampere Rating		American Wire Gauge			
More Than	Not More Than				
0	6	18	16	16	14
6	10	18	16	14	12
10	12	16	16	14	12
12	16	14	12	Not Recommended	

Safety Guidelines – Definitions

It is important for you to read and understand this manual. The information it contains relates to protecting YOUR SAFETY and PREVENTING PROBLEMS. The symbols below are used to help you recognize this information:

⚠ DANGER! Indicates an imminently hazardous situation which, if not avoided, will result in death or serious injury.

⚠ WARNING! Indicates a potentially hazardous situation which, if not avoided, could result in death or serious injury.

⚠ CAUTION! Indicates a potentially hazardous situation which, if not avoided, may result in minor or moderate injury.

CAUTION! Used without the safety alert symbol (⚠) indicates a potentially hazardous situation which, if not avoided, may result in property damage.

The label on your tool may include the following symbols:

v.....volts	a.....amperes
Hz.....hertz	w.....watts
Min.....minutes	~.....alternating current
—.....direct current	n ₀no load speed
□.....Class II Construction	⊕.....earthing terminal
⚠.....safety alert symbol	rpm.....revolutions or reciprocations per minute

Safety Markings

Drill Bit Sharpener

15,000 RPM 110•120V - 60Hz - 1.75A max / 0.77A nom

-or- 220•230V - 50Hz - 0.88A max / 0.4A nom

AC Only

Tool mass including detachable parts.

DD500X/DD750X Mass: 2.65 lbs = 1.202 kg.

Includes:

(1) DD500X or DD750X unit, (1) User's Guide, (1) wheel wrench

Noise and Vibration Emissions Values

Manufacturer: Darex, LLC

Model: DD500X/DD750X

Noise Emissions:

$L_d=L+K$, where the maximum $K = 3.0\text{dB}$ (per ISO 11201)

Declared value according to ISO 4817 at operator's position:

No load $L_{pa} = 76.9$ Loaded $L_{pa} = 89.7$

Measured Value according to ISO 3744 (half-sphere):

No load $L_{pa} = 72.0$ Loaded $L_{pa} = 75.0$

Vibration Emissions:

Measured vibration during normal work 1.9m/s^2 ; $K = 1.5\text{m/s}^2U$
(per ISO 5349 and ISO 5349-2)

Note#1: The declared vibration total value has been measured in accordance with a standard test method and may be used for comparing one tool to with another.

Note #2: The declared vibration total value may also be used in a preliminary assessment of exposure.

⚠WARNING! The vibration emission during actual use of the power tool can differ from the declared total value depending on the ways in which the tool is used.

⚠WARNING! Identify safety measures to protect the operator based on an estimation of exposure in actual conditions of use.

Intended Uses

- This drill bit sharpener is designed to sharpen twist style drill bits 3/32" - 1/2". (DD750X will sharpen up to 3/4".)
- Sharpening drill bits in the home or small shop.
- Use in clean and dry environments
- Use with a clean power source of the correct rated voltage and cycle.

Unintended Uses (Not permissible)

- This drill bit sharpener is not intended to sharpen chisels, screw drivers or other similar shop tools.
- This sharpener is not intended for industrial or commercial sharpening services.
- Not for use in wet and/or hazardous environments.
- Not for use with converters or alternate power supplies.

Getting to Know Your Drill Doctor®

You can also watch a User Video on www.drilldoctor.com to become a sharpening expert in minutes!

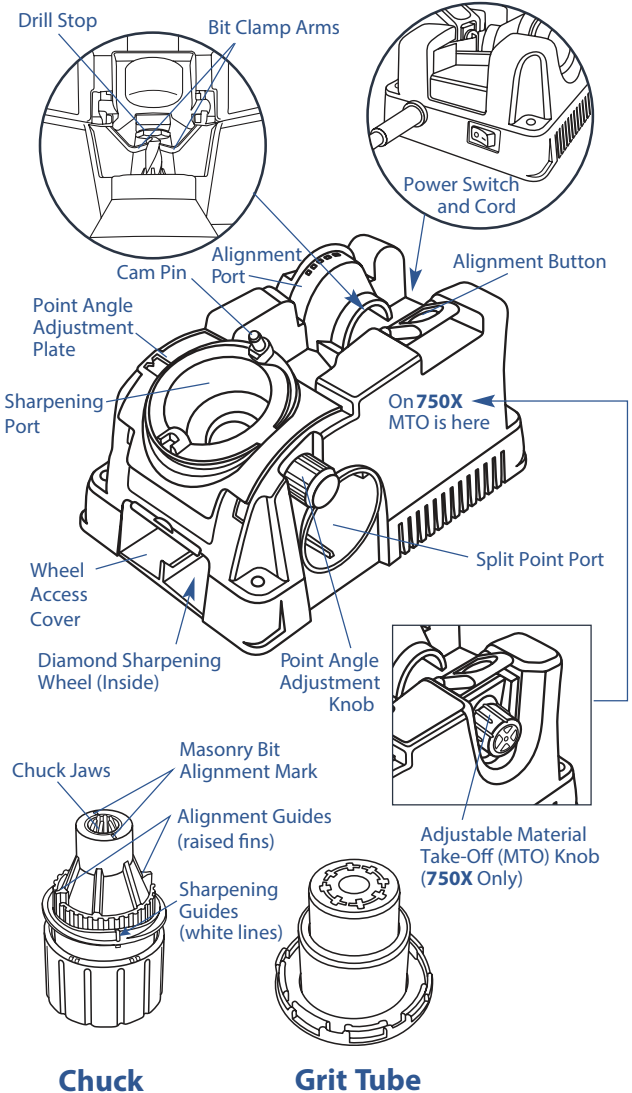

Identifying Basic Drill Bits

The **Drill Doctor**[®] is most efficient when used to sharpen a drill bit's original point angle. With its standard 180° Grit Diamond Sharpening Wheel it will sharpen high-speed steel, cobalt, TiN-coated, carbide and masonry drill bits. Your **Drill Doctor**[®] has been designed to sharpen the three most common drill bit types:



Standard Point

This general-purpose point (normally 118°) is used for drilling softer materials like cold rolled steel, aluminum, and wood.



Split Point

Split-point bits (normally 135°) are generally used for drilling into harder materials, like tempered steels, hard alloys or hard cast materials.



Masonry Bits

Masonry bits have a carbide insert at the point and are used for drilling materials like cement, brick, and ceramic.

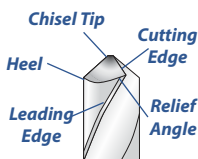

Anatomy of a Drill Bit

When viewing a well-sharpened bit from the side, the Heel will always be lower than the Cutting Edge; this is called "positive relief".

The Drill Doctor[®] Sharpening Process

The sharpening process includes 3 easy steps:

1. Align the bit in the Chuck.
2. Sharpen the bit (until there is no more grinding noise).
3. Split the point (optional on 118°, mandatory on 135°).

Be sure to complete each step to sharpen and split a bit and always sharpen the bit prior to splitting it.

Choosing Your Drill Bit Point Angle

Your Drill Doctor® allows you to sharpen bits with either the standard 118° or the flatter 135° point angle. You can also adjust the chisel and relief angle. (Refer to section “Adjust Chisel and Relief Angles”.)

Depending on what you are drilling in, you may choose to increase or decrease these angles.

On The Model DD500X

Check your drill bit angle

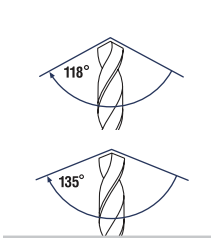

Most bits are 118° or 135°. Hold your bit point up to the key to the left to see which type your bit looks like. Most wood and soft metal applications require 118°. Harder materials such as stainless steel and tool steel require 135°. If you are drilling contoured materials (such as a car fender), plan on splitting the point to prevent walking of the bit.

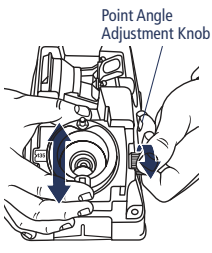

Choose the angle

Loosen the Point Angle Adjustment Knob on the right side of the Sharpening Port and slide the metal Point Angle Adjustment Plate to either the standard 118° or the flatter 135° point angle. Then re-tighten the Knob. The selected angle will show in the small window on the plate.

On The Model

DD750X

Choose the angle

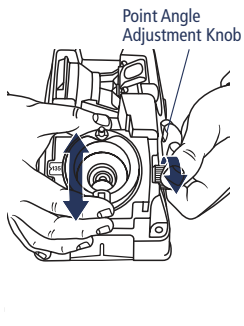

The Model DD750X has additional advanced features that enable you to fine-tune your bit geometry. Loosen the Point Angle Adjustment Knob to the right of the Sharpening Port and slide the metal Point Angle Adjustment Plate to standard 118° or 135° (or anywhere in-between, allowing you to create the custom angle of your choice.) Choose the point angle based on the application (material) you're drilling. Then re-tighten the Knob.

Aligning the Drill Bit

Proper alignment ensures your Drill Doctor will create the correct geometry on your bit. It also sets the drill stick-out, so that only a small amount of material is removed during sharpening.



1. Insert bit in Chuck and tighten

Insert the bit into the Chuck and close the Jaws just to the point where the bit slides in and out. Do not over tighten the Chuck; the bit needs to be able to move in and out until Step 4.

Model DD750X features an adjustable Material Take-Off. Refer to section: Using the Variable Material Take-Off to learn more.

2. Insert Chuck into Alignment Port

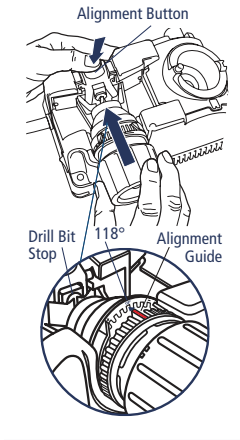

Press the Alignment Button down that opens the bit clamp arms. Insert either of the Alignment Guides (raised fins) on the Chuck into the 118° notch on the Alignment Port. With the clamp arms held open, slide the drill bit forward until it touches the Drill Stop. (Make sure the Chuck is seated all the way into the Alignment Port). Now release the Alignment Button, releasing the clamp arms.

When sharpening standard 118° drill bits, align in the 118° slot.

For standard 135° drill bits, align 1-notch to the right (-) of the 118° slot.

3. Adjust Bit Position

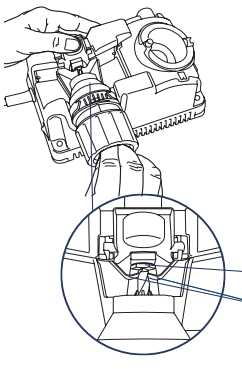

Check to ensure your bit is held in place correctly. The Clamp Arms should be holding the drill bit at its narrowest spot (in the flutes). If they aren't, turn the bit slightly until they fall into the flutes. This is an important step to proper alignment.

4. Lightly Tighten Chuck

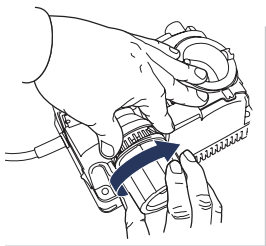

Hold onto the Chuck and tighten the Chuck Knob until it is snug. (Avoid over-tightening the Chuck in the Alignment Port as this could damage the alignment teeth in the port.)

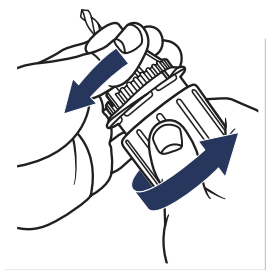

Press the Alignment Button and remove the Chuck from the Alignment Port. Tighten the Chuck once more to ensure the bit won't move when you sharpen it.

You are now ready to sharpen the drill bit!

Sharpening the Bit

Before sharpening you should know:

- **Keep the Chuck in contact with the Cam Pin at all times as you sharpen.**
- Only **light pressure** is required.
- You will hear a grinding noise (**zzzzZZzzzz**) as you complete each half-turn and each side of the bit face is ground.
- The sharpening port will rock as you rotate the Chuck.

1. Sharpening Guides

Insert Chuck into Sharpening Port with either of the Sharpening Guides (white lines) lined up with the Cam Pin on the machine.

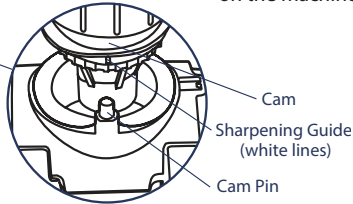
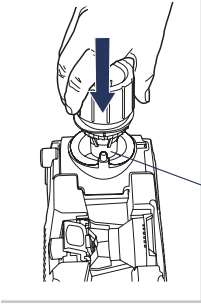

2. Sharpen Your Bit

Rotate Chuck in a clockwise direction (from white line to white line) until there is no more grinding noise. Ensure you are keeping Chuck up against Cam Pin at all times. Your motion should be smooth and even.

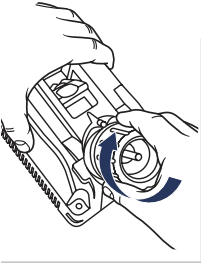

Different size drill bits may require a different number of rotations. Continue to sharpen until you no longer hear grinding noise. This will result in a Chisel Edge that is clean and straight and ensure the entire surface from the Cutting Edge to the Heel is finely ground.

Note: If splitting your drill bit, do not remove from Chuck after sharpening.

Identifying Correctly Sharpened Drill Bits (and what to do with those that aren't!)

Correctly Sharpened Bits

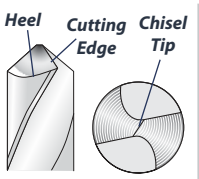

The entire surface from the Cutting Edge to the Heel will have a finely ground surface without indentations. The Heel will always be lower than the Cutting Edge (positive relief).

Once you have reached spark-out (no more grinding noise at all) take a look at your drill bit. The chisel angle should be between 1:00 and 1:30.

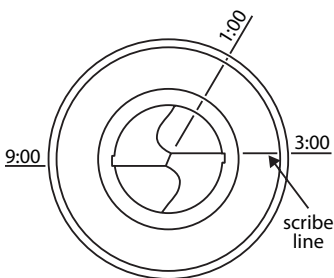

*Look at the bit: Hold the bit up and look at it with the cutting edges in line with the horizon (or parallel with the 9:00 and 3:00 position imagining a clock's face).

Now look at the chisel. It should be between 1:00 and 1:30. 2:00 is too far advanced, and if the

chisel gets too close to 12:00, the relief will be negative.

Too much relief will cause an oversized hole diameter and rapid bit wear. Too little relief will limit feed rates, slowing down the drilling operation or in extreme cases cause the drill not to perform at all.

If chisel angle looks to be about 2 o'clock, re-align bit 1-2 ticks to the right of the 118° mark (toward the minus sign) and re-sharpen.

If chisel angle is up to about 2:30, align 2-3 ticks towards the minus sign.

If chisel is about 12:45, it's at the low end of chisel & relief, re-align bit 1 tick to the left of the 118° mark (toward the plus sign) and re-sharpen.

Split Points

Split point drill bits prevent “walking” on the material before they begin to cut. This feature is described as self-centering. The need to center punch is effectively eliminated.

Split point drill bits have secondary cutting lips along the chisel edge. Up to 70% less thrust is required to drill a hole (when compared to a non-split or conventional point.)

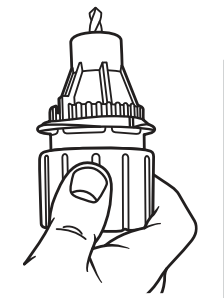

1. Splitting the Point

Leave bit in Chuck after sharpening

Always align and sharpen a bit before splitting it. To split the point, do not remove the bit from the Chuck after sharpening.

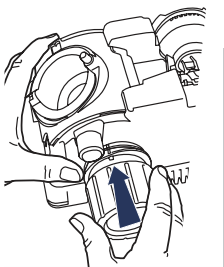

2. Align Guides

Remove the Grit Tube.

Line up one of the Chuck's Sharpening Guides (white lines) with the Splitting Guide on the Splitting Port.

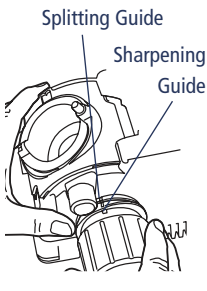

3. Split the point

Press Chuck slowly and firmly into the Splitting Port. Remove the Chuck, **rotate one-half turn**, and repeat.

Check the tip of the bit carefully to determine that both sides of the bit are split equally. Compare it to the following illustrations. If it does not match, study the information below.

Identifying (And what to do

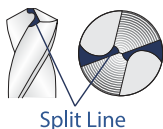

Correctly Split Drill Bits with those that are

Correctly Split

Solution

Split lines are nearly straight across.

Split lines do not meet in the center but Chisel Edge remains.

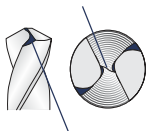

Not enough material has been removed from the Heel of the drill bit.

Undersplit

Solution

More grinding is needed for larger drill bits. If one side of the bit is under split, insert the Chuck into the Splitting Port again and split both sides. Repeat until the split sides are equal and look like the correctly split bit shown above.

Too much material removed.

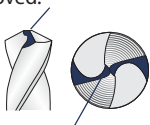

Split lines are joined in the center and Chisel edge has been removed.

Oversplit

Solution

Reinsert the chucked bit into the Sharpening Port and sharpen until the split tip looks like the correctly split bit above, checking every few rotations.

Grit Tube Attachment

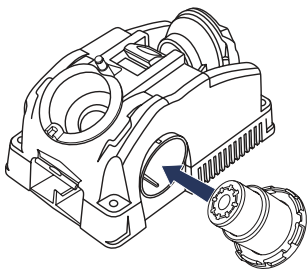

The Grit Tube attachment is designed to keep any sparks caused by sharpening safely inside the machine and away from you. In addition, the Grit Tube reduces the sharpening dust in the air and on your workbench.

Simply insert the Grit Tube into the Splitting Port of your Drill Doctor when sharpening. It will catch the grit that is formed from the sharpening process. Clean the inside of your Drill Doctor and the Grit Tube on a regular schedule. The grit tube is designed to accept a standard 1" shop vacuum for extended periods of sharpening.

Never clean with an air compressor, it may damage the machine. Use a brush or vacuum.

Sharpening Bits of Different Lengths, Diameters, and Types

Different size drill bits may require a different number of rotations. Continue to sharpen until you no longer hear grinding noise.

Large Drill Bits

The Model DD500X sharpens bits from 3/32" to 1/2". You can also purchase a Large Bit Chuck that sharpens bits up to 3/4". The Model DD750X comes equipped with that Large-Bit Chuck. It sharpens bits from 3/32" to 3/4".

Large bits are sharpened just like any other bit.

It is important to sharpen these bits so that the entire face of the drill bit is sharpened. A large bit requires more half-turns to sharpen it. It may take two or three complete sharpenings (repeat all steps) to resharpen a very dull or chipped large drill bit.

Using an optional 100-grit coarse wheel can speed up the process.

Short Drill Bits & Bits Smaller than 1/8"

Sharpen the small bit as usual, but use very light pressure and an even number of turns. The bit should only briefly contact the wheel.

Masonry Drill Bits

To sharpen a masonry bit, you do NOT make rotations in the Sharpening Port. Instead you sharpen by "plunging" - inserting the chuck to sharpen one side, then removing it and repeating on the other side.

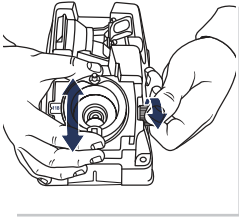

Set the point angle to 118°.

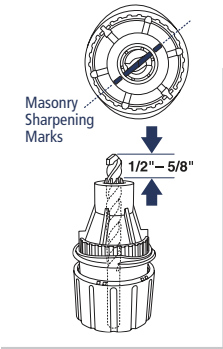

Align the bit with the Masonry Sharpening Marks

Insert the bit into the Chuck and line up the carbide insert on the tip of the bit with the Masonry Sharpening Marks on the end of the chuck. Leave about 1/2"-5/8" of bit sticking out past the nose of the Chuck. Tighten the Chuck just to the point where the bit slides in and out.

Set the Depth

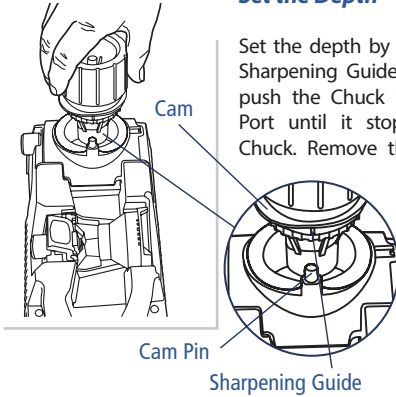

Set the depth by lining up one of the Sharpening Guides with the Cam Pin. push the Chuck into the Sharpening Port until it stops and tighten the Chuck. Remove the Chuck to ensure the insert is aligned with the Masonry Sharpening Marks and tighten again.

Sharpen by “plunging”

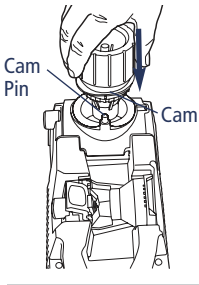

Line up the Sharpening Guide (white lines) on the Chuck with the Cam Pin on the machine. Plunge the Chuck into the Sharpening Port until it touches the Sharpening Wheel. Remove the Chuck, rotate one half-turn clockwise and repeat. Inspect the bit and continue until the cutting surfaces are sharp. If the bit stops grinding before the edges are sharp, reset the depth and sharpen some more.

Using the Variable Alignment to Adjust the Chisel and Relief Angles

Both models **DD500X** and **DD750X** enable you to adjust the Chisel and Relief Angles of your drill bit. The Chisel and Relief Angles have a direct effect on the performance of your drill. By increasing the Relief Angle, you can increase the speed of the drill in softer materials. To improve the quality of the hole, you can adjust the drill to be less aggressive. A less-aggressive drill has lower Chisel and Relief Angles. Your Drill Doctor enables you to adjust both angles in one setting.

1.



Chuck bit as usual

To prepare your bit for this fine adjustment, follow all the Steps for chucking your bit given previously in this User's Guide.

2.

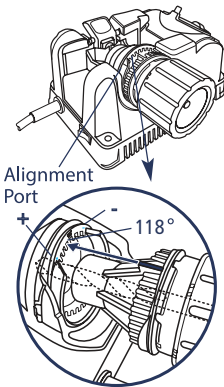

Insert Chuck into Alignment Port

To adjust the Chisel and Relief Angles, simply align the bit as usual with the following adjustment:

To increase Relief—Insert the Chuck in the Alignment Port closer to the (+) position. This will make a more aggressive drill point. Only adjust 1-slot at a time.

To decrease Chisel and Relief—Insert the Chuck in the Alignment Port closer to the (-) position. This will make a more precise hole. Take care not to adjust Relief too far as this will actually cause the drill to lose all Relief and therefore not drill a hole.

3.

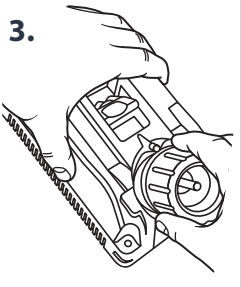

Each notch in the Alignment Port is approximately a 10° change in Chisel Angle.

Tighten Chuck, and sharpen as usual

Experiment with a few different settings to find the one that best suits your drill bit and application. You may find it helpful to mark this setting for future use.

Using the Variable Material Take-Off (MTO)

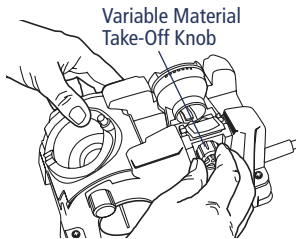

The **Model DD750X** enables you to remove more or less material from the tip of your bit when you sharpen. If your bit is only slightly dull and you simply wish to “touch up” its point, turn the Material Take-Off (MTO) Knob **clockwise** to reduce the amount of material that is

removed from the drill bit. If your drill bit is quite dull or damaged, turn the MTO Knob **counter-clockwise** to increase the amount of material removed. The MTO adjusts from 0 to .040 of an inch.

Each mark on the MTO knob is equal to a .005” change in material removed from the bit each time it is sharpened.

Questions and Answers

1. Question:

Why was my drill bit sharpened improperly?

Answer:

The most common cause of improper sharpening is incorrect alignment.

Key causes are:

- Chuck not inserted into the Sharpening Port correctly. Ensure the Alignment Guides (raised fins) are fitted into the correct alignment slot.
- Drill not aligned in the Chuck Jaws correctly. Ensure bit clamp arms are holding in the narrowest part of the bit.
- The type of drill requires an angle adjustment to achieve the desired Chisel and Relief Angles. Try using the Variable Alignment to adjust the Chisel and Relief Angle.
- Chuck is dirty or the bit slipped out of alignment.
- See “Cleaning the Chuck.”

2. Question:

When I aligned the drill bit and sharpened it, why was no material removed?

Answer:

Your sharpening tube may not be fully seated. Make sure the small, black sharpening cup is sitting flush in the Sharpening Port.

3. Question:

I sharpened the bit. Why will it not cut?

Answer:

This happens when the Heel on the bit is higher than the Cutting Edge (negative relief). You may have a specialty drill bit. Slow and Fast Spiral, Helix, Turbo Flutes, and Raised Margin drill bits are considered specialty bits. Follow the instructions in "Using the Variable Alignment to Adjust the Chisel and Relief Angle." If you're getting insufficient relief try aligning one notch towards the (+) setting on the alignment port.

4. Question:

What can I do about flat spots between the Cutting Edge and the Heel?

Answer:

The flat spots on a sharpened bit are the result of an incomplete or paused half-turn of the Chuck in the Sharpening Port. To correct, apply light, inward pressure and rotate the Chuck smoothly while sharpening. Be sure to complete the half-turns.

5. Question:

Why is the drill point off center?

Answer:

- Make sure there are no particles between the Chuck Jaws and the drill bit that could hold it off center. Check the drill to ensure it is straight and free of burrs.
- Your drill bit may be bent.

6. Question:

Why is the Chisel Edge on my drill bit flat or rounded?

Answer:

- You may have aligned using the white Sharpening lines instead of the raised Alignment Guides. Make sure to insert either of the raised fins into the correct alignment slot.
- During the alignment process the Bit Clamp Arms were gripping the high points of the drill bit. Realign the drill bit making sure that the Bit Clamp Arms are holding the drill bit in the narrowest section of the bit.

7. Question:

Why is my split point uneven?

Answer:

You may have used uneven pressure during the splitting process. To correct an uneven point split, insert the Chuck into the Splitting Port and split both sides again. Repeat until the split sides are equal.

8. Question:

Why does the drill bit back up into the Chuck during the sharpening procedure?

Answer:

- Your Chuck may be dirty. Follow the steps for cleaning the chuck.
- Your bit may have been loose in the Chuck. Make sure to tighten adequately before sharpening.

9. Question:

When splitting, why don't I hear a grinding sound?

Answer:

The Chuck is not seated properly in the Splitting Port. The Chuck's Sharpening Guide must line up with the Splitting Guide on the top of the Split Point Port. Firmly and slowly push the Chuck into the hole until you hear grinding.

10. Question:

Can I change a 135° drill bit into a 118° drill bit?

Answer:

While you can change the degree angle of any drill bit, they will perform best when sharpened at the same angle they were manufactured at.

Drill Doctor® Maintenance

After sharpening 20 to 25 drill bits, the drill bit grinding dust will accumulate in the grinding compartment. Grinding particles will promote wear in the Sharpening Port and Chuck, so cleaning on a consistent basis can add life to your machine.

Before any maintenance or cleaning is performed, be sure to unplug your Drill Doctor.

Removing the Wheel Access Cover

With the Drill Doctor unplugged, slide the Wheel Access Cover forward to remove. It will come completely off for easy access. To close, insert the Cover back into the slots and snap back in place.

Cleaning Your Drill Doctor®

With the Drill Doctor unplugged, shake accumulated drill bit grinding dust from behind the Wheel Access Cover into a disposable container. Remove dust particles around the wheel with a small, dry brush. Dispose of the container and drill bit dust in a safe and environmentally approved manner. With a dry cloth wipe the inside and outside of the Sharpening Port to remove any grinding dust that may have accumulated. A standard 1" vacuum hose works equally well.

Cleaning the Chuck

Brush out with a small, dry brush.

Determining if Replacing the Diamond Grinding Wheel Is Required

You get double the life of the Diamond Sharpening Wheel by reversing it before you replace it. The Sharpening Wheel supplied with the Drill Doctor® is designed to give you long and trouble free service, with an average of more than 200 sharpenings for 3/32" to 1/2" drill bits.

The Sharpening Wheel will need to be changed if:

- Your drill bit has a shiny, mirror finish.
- Your drill bits burn or turn blue on the tip.

Contact the store or dealer where you purchased the **Drill Doctor**, or contact **Drill Doctor** directly, to purchase a replacement Sharpening Wheel.

Reversing or Replacing Your Diamond Sharpening Wheel

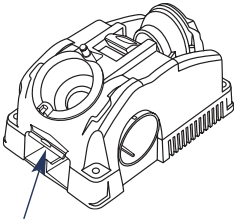

Wheel Access Cover

1. **Unplug your Drill Doctor**, make sure machine is cool, then remove wheel access cover.

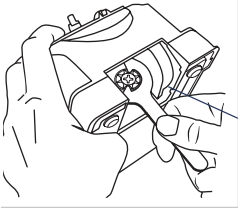

2. Use wrench supplied with your Drill Doctor to hold sharpening wheel in place.

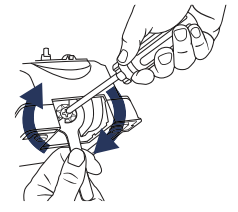
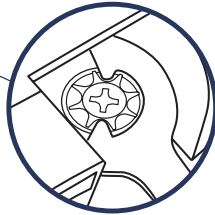

3. With #3 Phillips head screwdriver, remove one left-handed screw (clockwise to loosen) and remove the wheel retainer.

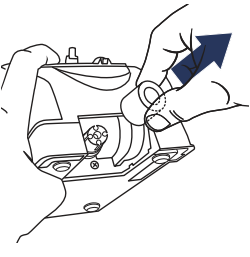

4. Remove worn wheel by twisting slightly and lifting wheel off shaft. Install new wheel and reinstall wheel retainer and screw. Don't over-tighten mounting screw (tighten to about 48 in/lbs). Remove the wrench and replace the Wheel Access Cover before turning on the machine.

Accessories

Order accessories by contacting us at the phone number listed on the back cover, or at the retailer where you purchased your Drill Doctor.



3/32" to 3/4" Large Bit Chuck
Part # DA70100PF

3/32" to 1/2" Left-handed Bit Chuck
(for 3/32"-1/2" reverse twist drill bits)
Part # DA02105PF



Standard Diamond Sharpening Wheel Kit (180 grit)
Part # DA31320GF



Coarse Diamond Sharpening Wheel Kit (100 grit)
Part # DA31325GF



⚠️WARNING:

The use of any accessory other than one recommended in this user's manual may present a risk of personal injury.

Drill Doctor® Warranty

Darex, LLC warranties your Drill Doctor to be free of defects due to workmanship or design for 3 years from the date of purchase.

For warranty service, contact your dealer with sales receipt.



Drill Doctor[®]
THE DRILL BIT SHARPENER

DAREX, LLC

P.O. BOX 730
210 E. Hersey St.
Ashland, OR 97520
USA

Phone

1-800-597-6170

Fax

541-552-1377

Web

www.DrillDoctor.com

Drill Doctor[®] is a registered trademark of DAREX, LLC